

NO	PART NO	PART NAME	SPEC	Q'TY	REMARK
1	TCM20-015-001-01	CAP	SM45C	1	-
2	TCM20-015-002-01	GUIDE BUSH HOLDER	SCM420	1	-
3	TCM20-015-003-00	SLEEVE PIN	SM45C	1	-
4	TCM20-015-004-01	BEARING HOUSING	SM45C	1	-
5	TCM20-015-005-00	LOCK NUT A	SM45C	1	-
6	TCM20-015-006-01	OIL SLINGER	SM45C	1	-
7	TCM20-015-007-01	PULLEY (P60-5GT-15)	SM45C	1	-
8	TCM20-015-008-01	ADJUST NUT	SM45C	1	-
9	TCM20-015-009-01	LOCK NUT B	SM45C	1	-
10	TCM20-015-010-00	ADJUST CAP	SM45C	1	-
11	-	BEARING	7908C	4	-
12	-	KEY	5x5x15	1	-
13	-	TAPER WITH INTERNAL THREAD	8x30	2	-
14	-	HEXAGON SOCKET HEAD CAP	M4x12	4	-
15	-	-	M6x20	4	-
16	-	-	M8x20	6	-
17	-	-	-	-	-
18	-	HEXAGON SOCKET FLAT POINT SET	M6x8	2	-

SURFACE FINISH
()

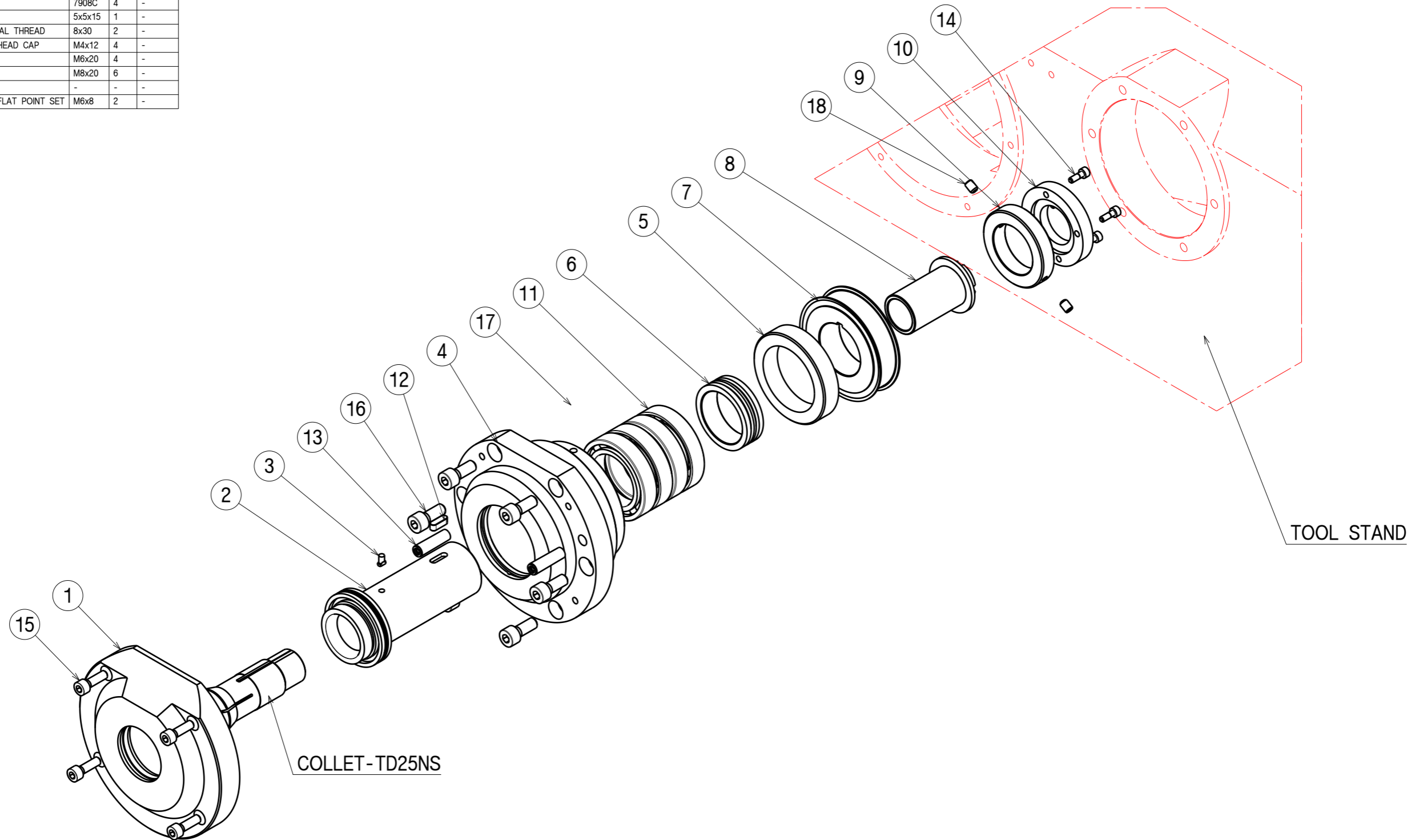

NO	DESCRIPTION	DATE	CHECK	TOLERANCE	DESIGN DATE	Q'TY	MATERIAL	SCALE	WEIGHT	DRWN	DSGN	CHKD	APRV
				GRADE=1	2016/07/04			1:1		DYKIM			
				SURFACE TREATMENT			PART NAME			2016/07/04			
				HEAT TREATMENT			GUIDE BUSH UNIT						
				MODEL	TCM20		DRAWING NO.						
				UNIT NAME	GUIDE BUSH UNIT		TCM20-015-A01-00						



A3 SHT NO. 1 / 2